



Transmitter -PLC Outdoor kit Quick installation guide

This installation guide is for customers who have purchased Transmitter -PLC-2 outdoor kit . if you have not purchased our outdoor kit, the following content is used as a reference.



NOTE: Install RSD before powering on the Transmitter.

- **Product dimensions (unit:mm)**

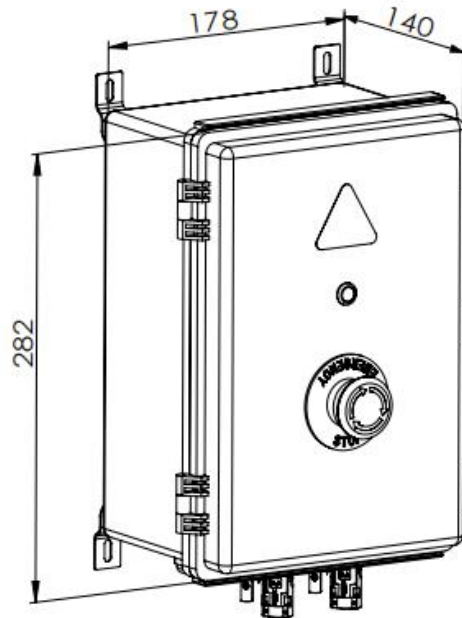

- Step 1: Fix the four feet with screws
- Step 2: confirm the emergency stop button in off state
- Step3: plug the pv string only one line(+)or (-) to Transmitter PLC outdoor kit
- Step3:connect the power supply (power plug, confirm the voltage in AC100~240V)

Attention : The step 3 only one line (+) or (-) , don't connect the one same string both line (+) and (-) to Transmitter PLC outdoor kit!! Otherwise will be damage!

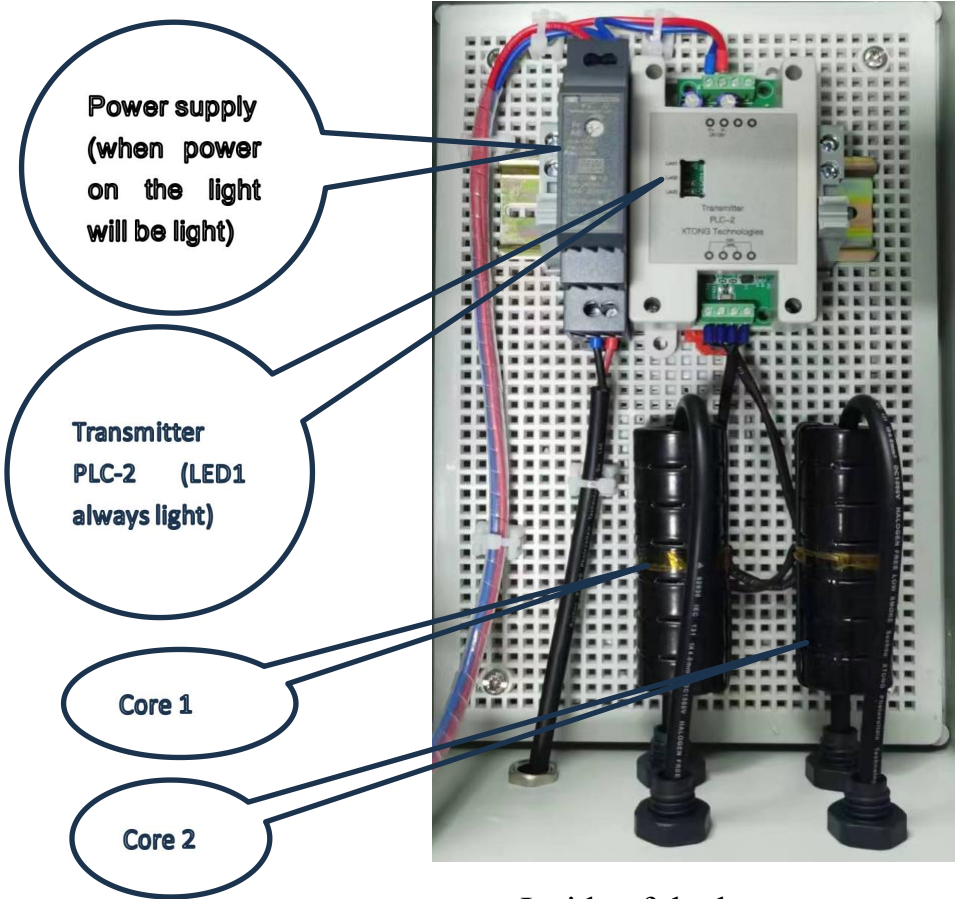

Inside of the layout

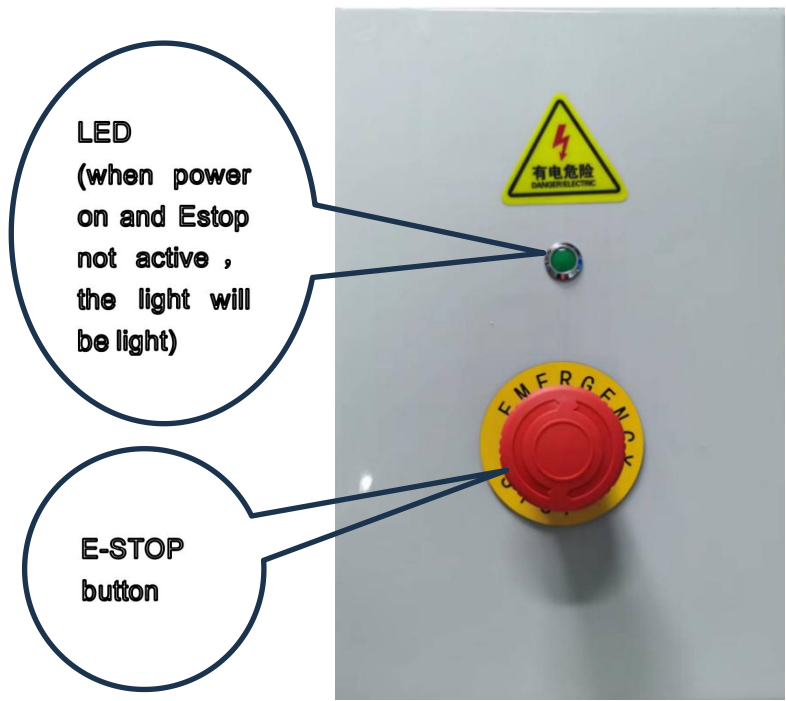

Fron of View

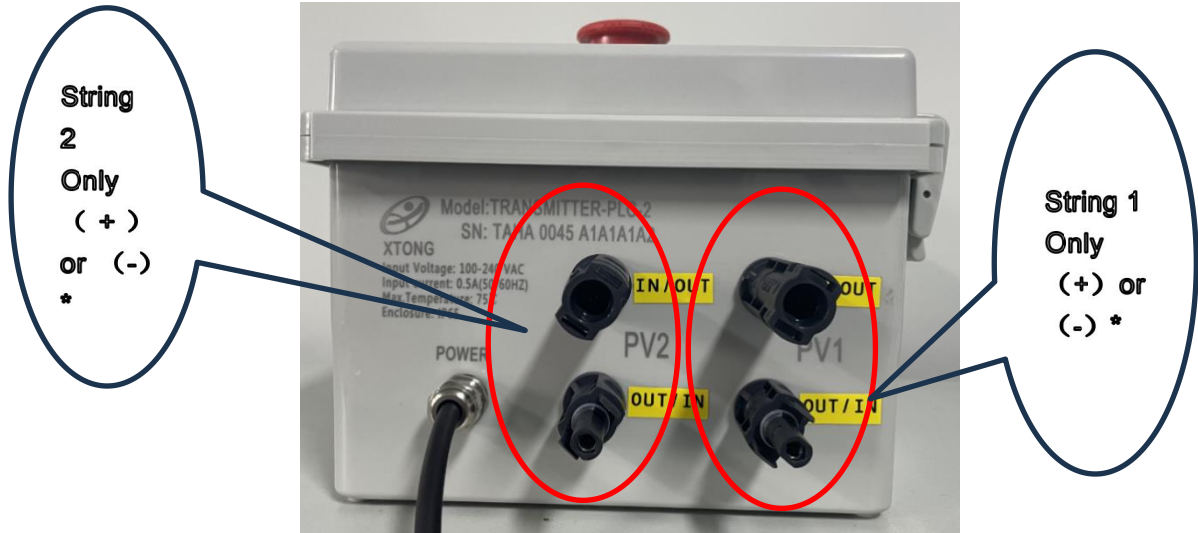

Bottom view

***Note: only one line (+) or (-) , don't connect the one same string both line (+) and (-) !**



Connector assembly tool

Pls use connector assembly tool to release the connector like below picture show:





● **System Wiring Diagram**

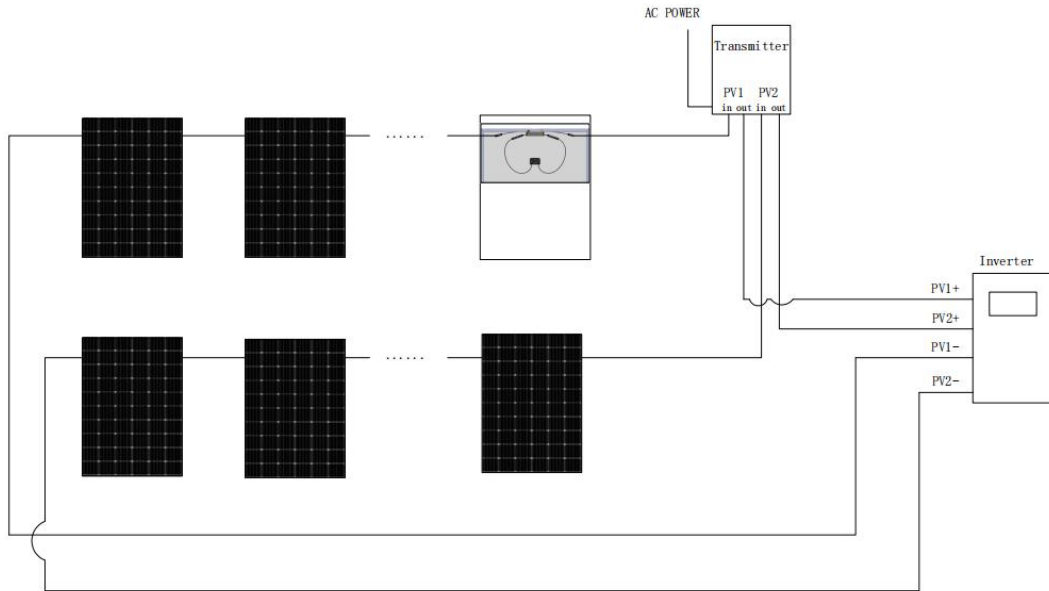

● **Main technical specifications**

Main electrical data

Input voltage	AC 100~240V
Input current	0.5A
Communication	PLC

Core data

Max. current	30A Per core
Max. system voltage	1500V DC
Internal Opening for Wires/Outside Dimensions	23.6mm/47.6mm
Max. Supported PV Modules per String	30 modules

Environmental

Temperature	-40°C~+60°C
-------------	-------------

Structure data

Dimensions(W*H*D)	282mm x 178mm x 140mm
Enclosure Environmental Rating	IP65



Features & Compliance

Safety Compliance	NEC 2017&2020(690.12):UL1741; CSA C22.2 No.330-17
EMC Compliance	FCC Part 15;ICES-003

TroubleShooting

Check that the system conforms to the design rules:

- Up to 30 modules (XRSD-xyz) per string;
- String length up to 1000ft (total cable length from + to -)
- DC cables through core must be the same polarity (all positive or all negative)
- Transmitter PLC kit front panel power LED and transmitter PLC-2 LED1 should be lit during operation
- Verify that core wiring is correct

Safety Instructions

1.The product should be assembled by people who were professionally trained and aware of related safety codes.

2.A set of specific PV Modules and tools is recommended to assemble the connectors. XTONG shall take no responsibility whatsoever for any problems caused by unspecified PV Modules or tools.

3.Do not deviate from the preparation and assembly steps described here. Do not modify the product in any way. XTONG shall give no guarantee as to safety or conformity with the technical parameter in the case of non-observance of XTONG’s manual or instructions.

4.Products cannot be stored, transferred or used in the environment that have the chemicals listed in Appendix Form 1 and labeled by “incompatible”.



(1) Do not over pressure, impact or pollute the products. XTONG shall take no responsibility whatsoever for any broken, shape change and other problems caused by over pressing, impact or pollution.

(2) The maximum storage time for this product is 1 year. Please assemble the product to end products within 1 year.

(3) The product must not be plugged together with any other connectors with different brands.

(4) Products shall not be used in non-PHOTOVOLTAIC systems or non-photovoltaic environments.

(5) The connectors cannot be used or operated under water or the rain.

(6) The unplugged connectors should be placed away from dust, water and pollution, and be protected by sealing caps.

(7) The connector should not be under continuously mechanical tension or stretching. The connectors or cables are recommended to be fixed.

(8) Cable which used to connect with the connector must be tin plated. PVC cables are prohibited for safety reasons.

 No actions mentioned in this document can be carried out on live or load-carrying parts.

 Electric shock protection is essential in final systems or assured by the end product and its user.

 Unplugging and plugging are not allowed when the system is under load.

 The same inverter is connected to more than two transmitters, and all the transmitters used need to be turned off when closed, otherwise there will be a situation of continuous shutdown.



Exclusion Terms

XTONG shall not be responsible for defects subjected to any situations as listed below

1. Inobservance in instructions or manuals from XTONG.
2. Connectors be plugged with a different brand connector.
3. Accident.
4. Connectors be used inappropriately.
5. Connectors be destroyed or broke by human.
6. Destruction or pollution caused by abnormal using environment.
7. Natural hazard.
8. Natural depletion.
9. Force majeure.

Xtong reserves the right of interpretation for this Specification and manual.

Suzhou XTONG Photovoltaic Technologies Co., Ltd

No. 5 Zhufeng Road, Mudu Town, Wuzhong District, Suzhou 215101,P.R.China

TEL:86-512-66796008

Fax:86-512-66796038

Email: sales@xtong-solar.com