

光伏连接器 PV Connector

XT2 | 技术参数 Specifications

型号 Type:	XT2
额定电压 Rated Voltage:	1500V
额定电流 Rated Current:	TUV:30A (2.5mm ²) / 41A (4mm ²) 46A(6mm ²); UL:35A (12AWG)
接触电阻 Contact Resistance:	≤0.5mΩ
温度范围 Temperature Range:	-40°C~+85°C
安全等级 Protection Class:	II
污染等级 Pollution degree:	1
防护等级 Degree of Protection:	IP68
防火等级 Flammability Class:	UL94V-0
绝缘材料 Insulating material:	PA/PC

特性 Features

广泛应用于近海、海面、植被茂密的高湿度环境项目
Widely used in offshore, sea, dense vegetation, high humidity environment projects



证书 Certification



PV-XT101.2 | 技术参数 Specifications

型号 Type:	PV-XT101.2
额定电压 Rated Voltage:	1500V
额定电流 Rated Current:	TUV:30A (2.5mm ²) / 41A (4mm ²) 46A(6mm ²); UL:35A (12AWG)
接触电阻 Contact Resistance:	≤0.5mΩ
温度范围 Temperature Range:	-40°C~+85°C
安全等级 Protection Class:	II
污染等级 Pollution degree:	1
防护等级 Degree of Protection:	IP68
防火等级 Flammability Class:	UL94V-0
绝缘材料 Insulating material:	MPPE/PC



证书 Certification



外形尺寸图 Overall dimension drawing

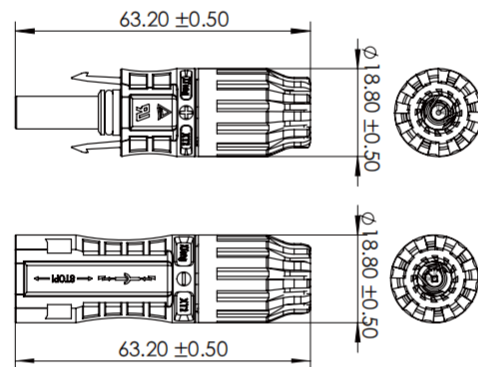

特性 Features

普遍应用于地面电站
It is widely used in ground power stations

尺寸优化, 适用更薄组件以降低包装材料的成本
Size optimization for thinner components to reduce the cost of packaging materials

外形尺寸图 Overall dimension drawing

